

FREEFALL FIRE VALVE MKII

The Landon Kingsway range of free-fall fire MKII valves provide a compact, leak-proof positive action mechanism that can be installed in either horizontal or vertical pipe runs on oil, gas or any non-aggressive media. The valve may be used for either cut-off or dump applications. All standard valves are manufactured in cast iron to ASTM A126 Gr B and are approved by both the American Gas Association and Canadian Gas Association, as well as being 'UL' listed.

The free-fall linkage allows the weight to start to fall before it is required to move the valve lever. This makes sure that the weight achieves sufficient momentum to overcome the initial stiffness of the valve.

Technical Specification

Material	Cast Iron, ASTM A126 Gr B
Finish	Powder Coated Red
Maximum Pressure	14 Bar (200psi)
Standard Cable	9m
Fusible Link	71°C as standard
Maintenance Req'd.	test & lubricate 3 times/year
Valve Rotation	90° (¼ turn)
Lubricant	2 ½" - 6" valves: 99015559 ½" - 2" : 99015560
Flange Spec	BS4504, PN16
Screwed Spec	BSP parallel
Weights Available	2.25, 4.5, 6.8kg (5, 10, 15lb)

Dimensions (not to scale)

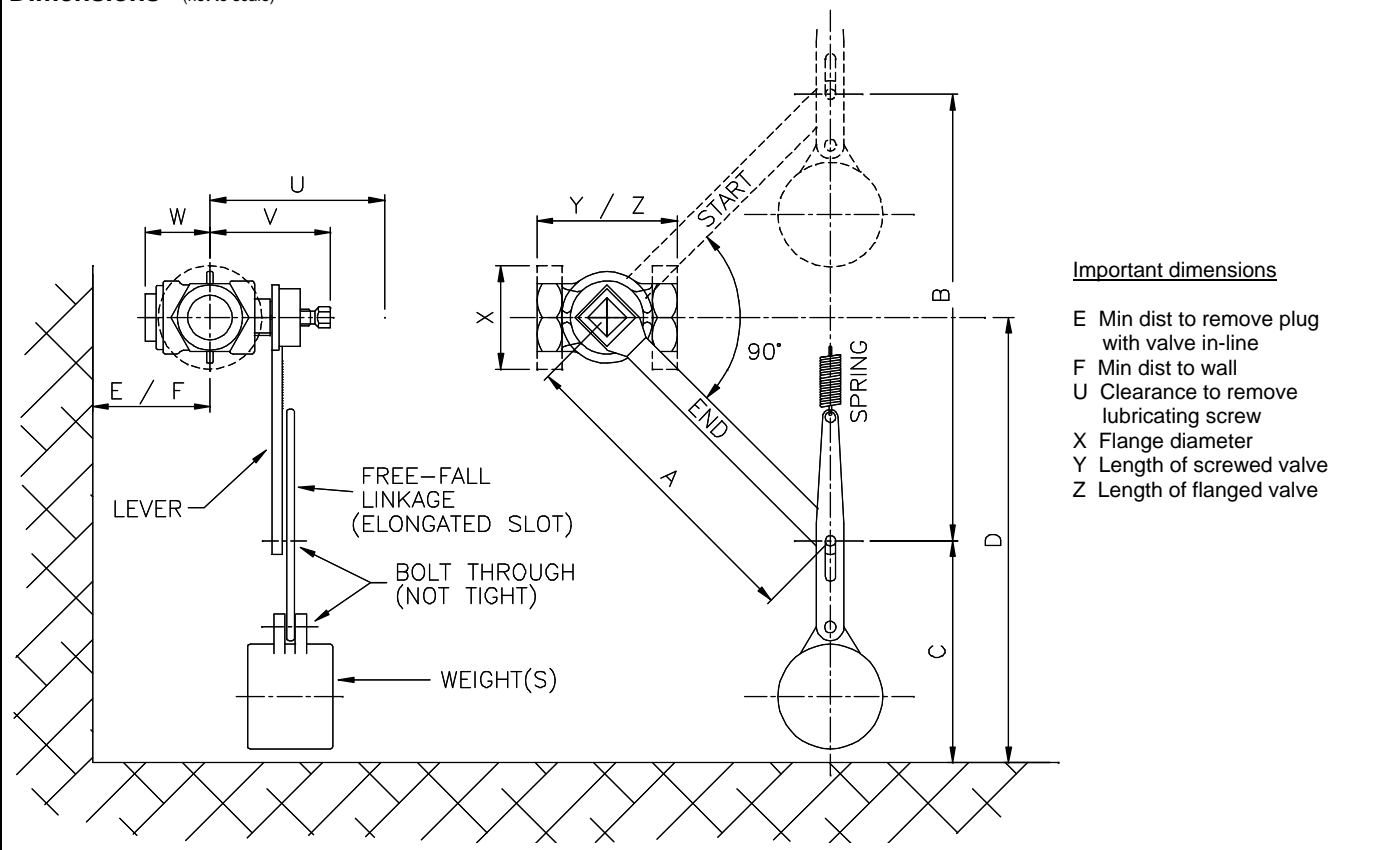

Valve Size	Lever	Z	Y	X	W	V	U	A	B	C	D	E	F	Weight
½"	10033102H (A Lever)		95	95	66	94	150	241	343	178	349	152	51	1x 5lb
¾"	10033102H (A Lever)		108	102	66	94	150	241	343	178	349	165	58	1x 5lb
1"	10033102H (A Lever)		128	114	66	94	150	241	343	178	394	191	64	1x 5lb
1¼"	10033202H (B Lever)		128	121	66	105	160	393	432	178	394	229	76	1x 5lb
1½"	10033202H (B Lever)		151	133	66	105	160	393	432	229	444	254	76	1x 10lb
2"	10033202H (B Lever)		170	152	85	125	160	393	540	229	502	330	102	1x 15lb
2½"	10034102H (D Lever)	200	204	197	110	165	200	783	540	229	502	330	102	1x 15lb
3"	10034102H (D Lever)	230	230	184	110	235	270	783	1092	251	800	457	152	1x 15lb
4"†	10034202H (E Lever)	230	—	216	110	235	310	649	864	251	683	470	165	2x 15lb
6"†	10034302H (F Lever)	266	—	279	160	235	370	737	1041	276	813	660	203	4x 15lb

† The 4" and 6" valves are only available in flanged versions.

FREEFALL FIRE VALVE

INSTALLATION

The valve may be installed in either horizontal or vertical pipe providing it is oriented such that the plug is parallel to the ground. Ensure that any pipe expansion or misalignment will not distort the valve body as this will cause it to stick.

Fit the lever onto the square valve shaft and tighten the fixing screw. Make sure that the lever travels freely from 45° up to 45° down.

Attach the free-fall linkage and weight(s) to the lever using the supplied nuts and bolts as shown in the diagrams. If using a 4", 5" or 6" valve, multiple weights and the pulley arrangement must be used as shown below. DO NOT tighten the bolt through the lever and free-fall link too tight as the free-fall link MUST be able to slide freely.

Finally fit the spring and cable to the top of the free-fall link. The cable should run vertically from the spring to the first pulley. The cable should then pass over any anticipated fire hazards with fusible link(s) installed in the cable 0.3 to 1.0m above the hazard. The cable may then be routed to a manual quick release by the exit or terminated at a wall anchor by means of crimping.

Note: When using a manual quick release, the distance from the release to the first pulley must be greater than the movement of the arm (B).

To crimp cables together, pass the two wires through a cable connector and crimp using a pair of pliers.

Lift the valve lever into the START/UP position and make sure that the lever pin is at the bottom of the elongated slot in the link. Use the spring/wire strainer to tension the cable.

NOTE: The close proximity of the flange to the body does

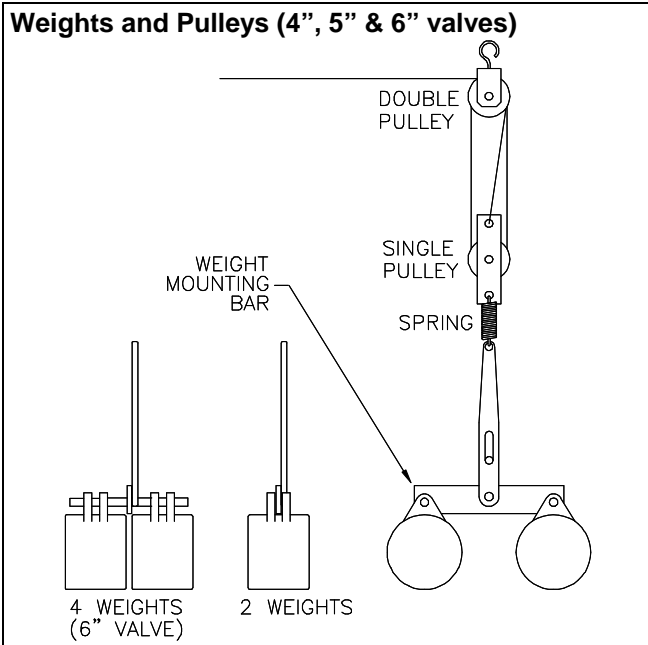

not allow room for all bolt holes to be drilled through on the larger valves. The holes are therefore tapped M16 on 4" and 5" valves and M20 on the 6" valve.

Standard Parts & Spares

No. = Standard Quantity

- 1 Lever (sizes A to F depending on valve size)
- 1 Free-fall elongated slot link
- 9m Cable - s/steel (30m, 150m, 300m, 760m avail.)
- 2 Brass woodscrew hooks with pulleys
- 1 ¼" BSP screw hook with pulley
- 1 Brass wall anchor
- 1 Turnbuckle/wire strainer (for valves ≥ 2" BSP)
- 1 Weight mounting bar (for valves ≥ 4")
- 5 Cable connectors (soft tube)
- 1 Tension Spring (light / heavy types)
- 1 Fusible link 71°C (std.), 92°C, 104°C, 127°C, 143°C, 180°C avail.
- 1 Warning notice to hang on cable
- 1 Double Pulleys (for 4", 5" & 6" valves)

TEST

Release the cable by releasing the quick release mechanism. The valve should close in a controlled manner with the lever travelling through a full 90°.

If the valve does not travel through the full 90° (¼ turn):

- Check for physical obstruction of the lever and weight(s) E.g. pipework
- Check the fusible link(s) and cable joins do not jam against pulleys
- Make sure that the cable is fitted around the pulleys and has not slipped off
- Lubricate the valve if stiff (see below)

LUBRICATION

If using a grease injection gun, connect to the grease nipple at the end of the lubricating screw. If lubricating by hand remove the lubricating screw from the end of the square shaft. Fill the reservoir inside the shaft with lubricant and replace the screw. Tighten the screw until a definite increase in resistance is felt, inserting further lubricant as necessary. 'Pump' the valve lever up and down several times to ensure the valve is free-moving.

If you have any questions or need any help then please

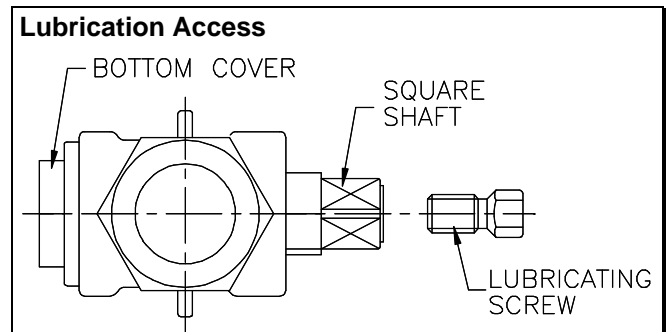

contact our sales office.