

109039XX G SERIES FREE FALL FIRE VALVE

The G series Free Fall Fire Valves are an essential part of fire protection systems. These valves are used for isolation of the fuel supply. Activated by the melting of a fusible link or by ancillary items such as manual quick release, panic buttons, Solenoid Quick Release (electrical) intervention with main fire alarm / BMS communication. Positional feedback can be achieved by incorporating a non-mercury tilt position switch.

The valve is held open by an anchored stainless-steel cable routed around a pulley system, the fusible link is positioned within the cable near to the potential heat source. When the cable is released, by melting of the fusible link, manual or electrical intervention the tension is released from the system allowing the free-fall linkage and weight to freely fall before it is required to move the valve lever, this provides sufficient momentum for reliable operation and allows the valve to close.

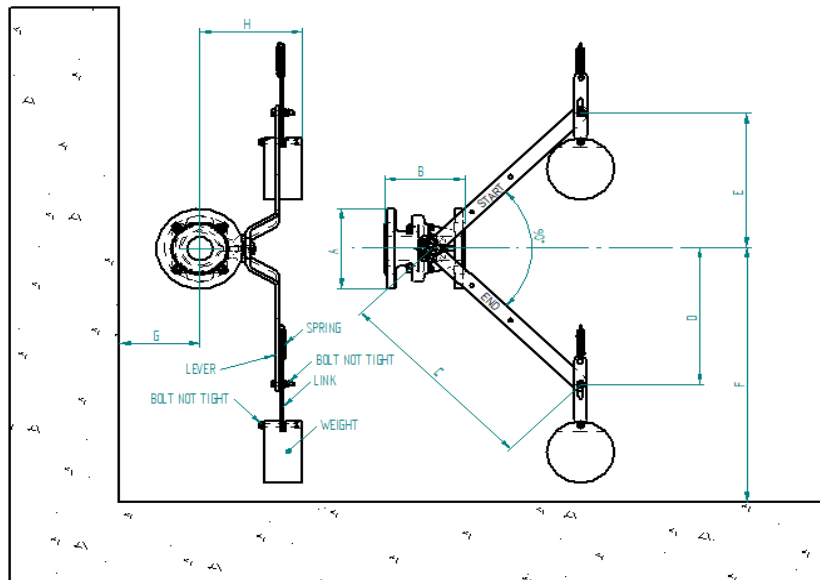
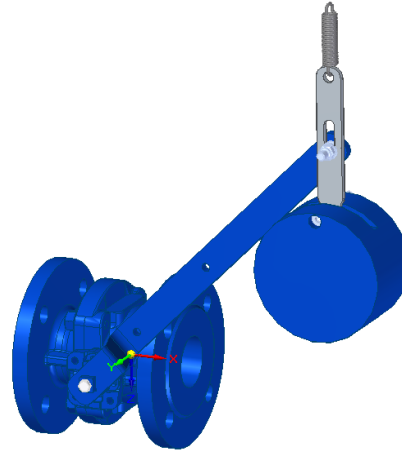

Dimensions (not to scale)

Kit Part Number	Valve Size	Connection	A	B	C	D	E	F	G	H	Weight
10903902H	½"	Flanged PN16	95	115	400	285	285	435	70	142	2.5Kg
10903905H	¾"	Flanged PN16	105	120	400	285	285	435	70	142	2.5Kg
10903910H	1"	Flanged PN16	115	125	400	285	285	435	70	150	2.5Kg
10903914H	1 1/4"	Flanged PN16	140	130	400	285	285	470	95	205	4.5Kg
10903918H	1 1/2"	Flanged PN16	150	140	400	285	285	470	95	205	4.5Kg
10903921H	2"	Flanged PN16	165	150	400	285	285	470	95	205	4.5Kg
10903926H	2 1/2"	Flanged PN16	185	170	400	285	285	500	115	205	7.0Kg
10903930H	3"	Flanged PN16	200	180	600	420	420	645	115	205	7.0Kg
10903934H *	4"	Flanged PN16	220	190	600	420	420	645	120	230	14.0Kg
10903938H *	5"	Flanged PN16	250	200	600	420	420	660	135	315	18.0Kg
10903940H *	6"	Flanged PN16	285	210	600	420	420	675	155	330	28.0Kg

* If used with SQR Compound pulley system should be incorporated, 10904701 required

109039XX G SERIES FREE FALL FIRE VALVE

INSTALLATION

The valve may be installed in either horizontal or vertical pipe. Ensure that any pipe expansion or miss-alignment will not distort the valve body as this will cause additional valve friction.

Fit the lever onto the valve shaft and tighten the fixing screw. Make sure that the lever travels freely from 45° up to 45° down.

Attach the free-fall linkage and weight(s) to the lever using the supplied nuts and bolts as shown in the diagrams. DO NOT tighten the bolt through the lever and free-fall link too tight as the free-fall link MUST be able to slide freely.

Finally fit the spring and cable to the top of the free-fall link. The cable should run vertically from the spring to the first pulley. The cable should then pass over any anticipated fire hazards with fusible link(s) installed in the cable 0.3 to 1.0m above the hazard. The cable may then be routed to a manual quick release (MQR) by the exit or terminated at a wall anchor by means of crimping. The system can also be incorporated with a solenoid quick release device (SQR) that allows for remote emergency activation electrically.

Note: When using a manual quick release, the distance from the release to the first pulley must be greater than the movement of the arm.

To crimp cables together, pass the two wires through a cable connector and crimp using a pair of crimp pliers part number STD66-100.

Lift the valve lever into the START/UP position and make sure that the lever pin is at the bottom of the elongated slot in the link. Use the spring/wire strainer to tension the cable.

TEST

Release the cable by releasing the quick release mechanism. The valve should close in a controlled manner with the lever travelling through a full 90°.

If the valve does not travel through the full 90° (¼ turn):

- Check for physical obstruction of the lever and weight(s) E.g. pipework
- Check the fusible link(s) and cable joins do not jam against pulleys
- Make sure that the cable is fitted around the pulleys and has not slipped off

If you have any questions or need any help then please contact our sales office.

Standard Parts & Spares No. = Standard Quantity

1	Lever (sizes depend on valve size)
1	Free-fall elongated slot link
9m	Cable - s/steel (150m, 300m, 760m available)
2	Brass M6 hooks
1	Turnbuckle tensioner
5	Cable connectors (soft tube)
1	Tension Spring
1	Fusible link 72°C (std.), 92°C, 103°C, 128°C, 133°C, 145°C, 183°C available.
1	Warning notice to hang on cable

Technical Specification

Body Material	Ductile iron EN GJS 400-15
Ball and Stem	Brass Chrome plated CuZn40Pb2
Ball Seat	Carbon Reinforced PTFE
Elastomers	NBR
Retaining Ring	Stainless Steel 302
Nuts Bolts Washers	Carbon Steel Galvanised
Handle	Carbon Steel Galvanised
External Finish	Powder Coated
Maximum Pressure	16 Bar
Temperature	-10°C ÷ 70°C
Standard Cable	30m
Fusible Link	72°C as standard
Valve Rotation	90° (¼ turn)
Flange Spec	BS4504, PN16

100% Tested in accordance with EN12266 Cat A ISO 5208 Cat A

PED directive Compliant 2014/68/UE

Ball valve DVGW certified for gas to EN13774 for gas distribution systems.

Conforms to AS4617:18 for use on natural gas (NG), simulated natural gas (SNG), town gas (TG), tempered liquefied petroleum gas (TLP) and liquefied petroleum gas (LPG) in vapour phase.

MAINTENANCE

Landon Kingsway recommend the G series Free Fall Fire Valve is checked for operation a minimum of 3 times annually, this check should be recorded. The operation of the system can either be checked by incorporating a manual quick release, solenoid quick release or by melting the fusible link.